



Z3000™

EQUIPMENT MANUAL VERSION 2.0
INSTRUCTION MANUAL & USER GUIDE

NORVELL®

Z3000™

Norvell, A Division of Sunless Inc., the leader in designing, developing, and Manufacturing state of the art spray tanning systems for use within professional Salons, Spas, Health Clubs, Med Spas, and Tanning Salons is proud to introduce the **Norvell Z3000** tanning system.

Our goal is to provide the highest quality tanning results along with unparalleled customer service, support and technology. As a customer having committed to such an investment you deserve nothing less.

—
WELCOME TO THE FUTURE OF SUNLESS.

IMPORTANT!

REGISTER YOUR EQUIPMENT TO RECEIVE THE MOST OUT OF YOUR PURCHASE AND TO INITIATE YOUR EQUIPMENT WARRANTIES.

Record your equipment serial numbers below:

MOBILE Z3000 TURBINE: Z3-



NOTE

Please read this manual carefully and thoroughly before operating your Arena. This manual contains important operation instructions and safety information. Retain this manual for future reference.

General Safety Information

Your safety and the safety of others is very important. Please read and obey all safety messages outlined below.

Electrical Requirements

Z3000 SPRAY UNIT: 115-120VAC, 5.5A, 60 Hz,

Z3000 SPRAY UNIT: 115 (ALT)-120VAC, 7.5A, 60 Hz,

(A GFCI 110V OUTLET IS RECOMMENDED) OR

Z3000 SPRAY UNIT: 220-240VAC, 3.5A, 50/60 Hz

It is the responsibility of the owner and operator to comply with all appropriate safety and health laws, as well as other applicable national, state and local laws and ordinances when operating and maintaining Norvell equipment. When using an electrical appliance, basic precautions should always be followed.

Norvell Equipment is to be operated only by those who have been professionally trained. Complete interactive training courses are available through Norvell University. The class schedule can be found online at www.norvelluniversity.com.



WARNING!

To reduce the risk of burns, fire, electrical shock, death or injury to persons, read the following important safety precautions and all instructions before operating/using the Norvell Z3000. Interior components are not to be disassembled except by trained and qualified personnel.

READ ALL SAFETY INFORMATION PROVIDED BELOW BEFORE USE:

- Carefully read this manual and follow all instructions given herein.
- Heed all warnings laid out in this manual, as well as, all warnings located on the unit.
- Use this product only as intended per the instructions in this manual.
- Do not use attachments or accessories unless recommended and authorized by Norvell.
- Use only genuine manufacturer replacement parts.
- Only spray liquids/fluids through the unit that have been approved by the equipment manufacturer.
- Do not spray flammable or combustible liquids, such as gasoline, or use in areas where they may be present.
- Do not use without the filters in place.
- Position the turbine unit outside of the spray area to prevent overspray from being recirculated through the turbine air intake. Overspray buildup inside the unit will damage the turbine motor and void all warranties.
- Make sure the room is well ventilated. Avoid all ignition sources, such as static electricity sparks, open flames, hot objects, sparks from connecting and disconnecting power cords, and working light switches.

- In Mobile situations, always position the turbine behind the spray technician.
- Do not spray into switches or power sockets.
- Do not allow the unit to run unattended.
- Unplug from outlet before cleaning, troubleshooting and/or servicing.
- Do NOT allow to be used as a toy. Close attention is necessary when used by or near children.
- This product is not intended for use by persons (including children) with reduced physical, sensory or mental capabilities, or lack of experience and knowledge, unless they have been given supervision or instruction concerning use of the appliance by a person responsible for their safety.
- The use of a respirator, mask, or nose filter whenever there is a chance that vapors may be inhaled, especially with prolonged usage is recommended.
- Consult a physician before use if you are pregnant or think you may be pregnant, or if you have a diabetic condition.
- Norvell sunless solutions are not a sunscreen or a substitute for proper sun protection.
- Indoor Use ONLY. Do not use outdoors or on wet surfaces.
- Do not use your spray tan equipment near bathtubs, showers, basins, or other vessels containing water.
- Do not immerse any portion of equipment in liquids. Do not operate the spray gun if it is wet or leaking.
- Do not allow water to accumulate on the floor around the unit.
- Never handle the plug, cord, base unit, or spray gun with wet hands.
- To reduce the risk of fire or electric shock, do not expose this unit to rain or moisture.
- Do not overload wall outlets. Overloaded wall outlets, loose or damaged wall outlets, extension cords, frayed power cords, or damaged or cracked wire insulation are dangerous. Any of these conditions could result in electric shock or fire.
- Do not use the equipment if power cord is damaged. In the event of damage, discontinue use immediately. If the supplied cord is damaged, it must be replaced by an authorized Norvell technician.
- Protect the power cord from physical or mechanical abuse, such as being twisted, kinked, pinched, closed in a door, or walked upon. Pay particular attention to plugs, wall outlets, and the point where the cord exits the unit.
- Keep all electrical cord away from heated surfaces.
- Turn off all controls before unplugging. Do not unplug by pulling on cable. To unplug, grasp the plug to remove from outlet, not the cable.
- Do not use an extension cord unless the cord complies with local region electrical safety standards.
- Periodically inspect the power cord for signs of damage.
- Do not use the equipment with a voltage inverter or any device designed to convert the electrical supply from a different source. If the provided plug does not fit into your outlet, consult an electrician for replacement of the outlet.
- Do not modify the machine plugs.
- Always plug the power cord into a properly configured grounded outlet.



DO NOT PULL
ON CABLES



DO NOT SUBMERGE IN
WATER OR GET WET



DO NOT USE
NEAR OPEN FLAMES

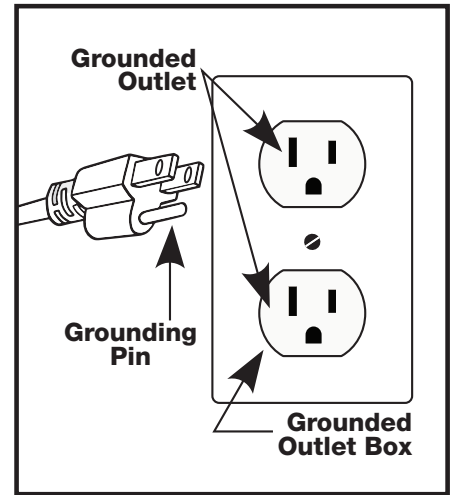

Fig. 1

Z3000™

Package Contents

Z3000 CONTENTS

- 1 - Mobile Z3000™ Turbine Unit
- 1 - 10ft Auto Lock Power Cord
- 1 - HVLP Pro Series Spray Z-Gun™
- 1 - Air Hose
- 1 - Operator's Manual



Inspect All Contents

Carefully unpack all packages and inventory contents upon arrival.

All missing or damage claims must be made to Norvell Customer Service ASAP by calling 888.829.2831 or 615.529.1250. Norvell must be notified of any damaged or missing items within 7 business days from the date of receipt.

Z3000™

Norvell Mobile Z3000 System™

The Norvell Z3000 HVLP Turbo spray tanning system has three components:

(1) Turbine unit (2) Air Hose and (3) Spray Gun.

The turbine unit when connected to the correct electrical power supply in the "on" position provides a continuous source of clean, warm, and dry High Volume Low Pressure (HVLP) air. The air hose connects the turbine unit to the Spray Gun. Air flows through the hose to the nozzle of the specially designed Z3000 Spray Gun. Atomization of the tanning solution is achieved when the air mixes with the stream of fluid passing through the tip/nozzle. This low-pressure atomization principle achieves minimal overspray (wasted spray) to the environment when applied correctly.

- The Z3000 Turbine unit has one air hose outlet on the top of the case and is designed to run one only one Spray Gun at a time.
- Your Norvell Z GUN offers many options. You can adjust (turn/click) the air cap (Fig. #1, on page 4) below to three positions. One will produce a horizontal pattern for spraying across, another will produce a vertical pattern for spraying up and down, and the third will produce a round pattern for detailing muscles or other intricate parts of the body.

SPRAY PATTERN DIAGRAM: (ZGun air-cap/nozzle spray pattern positions)

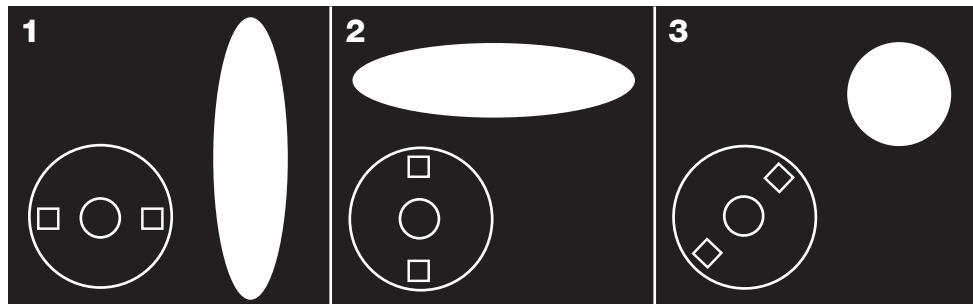

Z3000™

Familiarizing Yourself with Your ZGun™

Familiarize yourself with the controls on the Spray Gun. There are three principal controls.

(1) Rotating Air Cap (2) Solution Flow Control Screw and (3) Air Cap Locking Ring.

Click the Rotating Air Cap into each position. Horizontal, Vertical and 45° diagonal. When the air cap is in the 45° position the pattern is round, this is useful for spraying detail areas such as muscle toning or contouring. Flow will increase when using the diagonal position and it is usually necessary to reduce the flow by adjusting the flow screw.

Turn the Solution Flow Control Screw counter-clockwise to open or release more fluid, clockwise to close or reduce solution flow.



Preparing to Use Your Norvell Z3000™ Spray Tanning System for Mobile Operation

1. Select a safe, well ventilated area where you will spray your client. Locate your Norvell Z3000 turbine unit away from the area where you will be directly spraying so you can keep the filters cleaner. Do not cover or enclose the turbine unit in anything other than the authorized Norvell Quiet Box or the Norvell Pro Travel Bag.

NOTE: Place the Mobile Z3000 Unit in an area that will be behind the spray technician.

2. Connect the Air Hose to the turbine unit. Pull back the spring loaded quick disconnect coupler and insert the male connector on the air hose into the quick disconnect. Release the ring. Your air hose will be locked into place.

CAUTION: If you have just finished spraying, the metal coupler at the turbine end may be hot, use caution when removing the hose.

3. Connect the Pro Series HVLP ZGun to the Air Hose. Pull back the spring loaded quick disconnect coupler and insert the male connector of the Z Gun into the quick disconnect. Release the ring and the Z Gun will be locked into air hose.
4. Install the Mobile Electrical Cord (Provided) into the front of the Z3000 Unit. Plug the electric cord into a correctly grounded electrical outlet. Be sure the electric current is the correct voltage. If you need to use an extension cord, be sure it is at least 12-gauge wire and has a correctly grounded outlet. (240v units for use outside of the United States are often only supplied with an electric cord. A correct plug must be installed prior to use. Make sure the ground wire is properly connected).
5. It is important to draw cool/ambient air through the turbine unit for optimum performance and motor longevity. Avoid placing the turbine in a warm environment or in direct sunlight.

Preparing to Spray

Quality results with the Norvell spray tanning system is a combination of: careful client preparation, a proper spraying environment, a basic knowledge of the sunless solution technology and how these solutions work with the Norvell Mobile Z3000 spray tanning system.

The Norvell Mobile Z3000 turbine unit is designed to run at maximum speed. Make sure the filters are in place prior to operation. Press the On/Off switch on the rear panel to start the turbine unit.

Proper Spray Technique

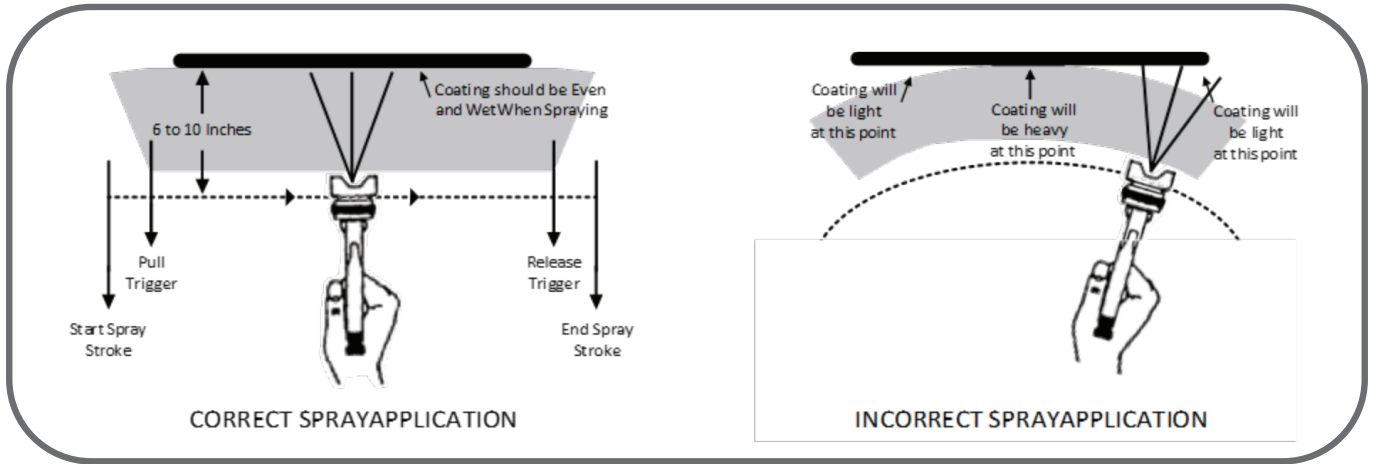

Using Your ZGun

- The Norvell ZGUN is certified, meaning your Spray Gun only uses approximately 3psi or less. All passages and air ports are much larger than an airbrush system. If one of these air passages becomes blocked, or buildup of solution starts to occur, your spray pattern will become distorted. Therefore, always keep your Spray Gun clean.
- Your ZGun comes fitted with a custom size tip/nozzle (Z Gun Fig. item #6 and needle (Z Gun Fig. item #15). This size has been designed to perfectly atomize a variety of UV Sunless tanning solutions. Using this size tip/nozzle and needle you can achieve between a 1/4" to 7" fan pattern, simply by rotating the air cap (Z Gun Fig. item#2) to the desired fan type (See Spray Patterns, Gun Fig. above), opening the material flow screw (Z Gun Fig. item#18) counter-clockwise and moving the Spray Gun closer or further away from the client. A little practice will enable you to master this very easy technique.
- **PRACTICE:** Remove the cup from your Spray Gun. Fill the Spray Gun Cup approximately half way with water or DHA FREE Training Solution.
- Re-attach the cup to the body of the Spray Gun. Attach the Spray Gun to the air hose. Turn the turbine unit on. You will notice air is now flowing through the air cap, this is normal and correct. Position the air cap (Z Gun Fig. item#2) in the horizontal position; turn the solution flow screw (Z Gun Fig. item#18) counter clockwise approximately 1 to 1 1/2 turns. Point the Spray Gun away from yourself (and anyone else) and pull the trigger all the way back. You should see a "V" shaped mist (or triangle) called a fan pattern.
- Now, with the trigger depressed, slowly begin to turn the solution flow screw (Z Gun Fig. item#18) clockwise (closing the solution flow). Notice that the fan pattern is beginning to get smaller.
- Now, reverse this and notice the pattern get larger. Take a large piece of cardboard or paper and direct the pattern at the surface. Turn the solution flow screw 2 full turns and hold the Spray Gun approximately 6" from the surface.
- Pull the trigger. Observe the outline and size of the pattern. Now, turn the solution flow screw clockwise (closing the solution flow). Move the Spray Gun an inch or two closer to the surface of the paper. Pull the trigger. Notice the pattern has become smaller.
- You can continue reducing the solution flow and move the Spray Gun even closer to the paper and the pattern will continue to get smaller and smaller. Next, rotate the air cap to a diagonal 45° position (See Spray Patterns, Spray Pattern Fig. above). Vary the solution flow and the distance of the Spray Gun from the work surface. Notice the change in pattern size.

▲ CAUTION

CAUTION

Even when the turbine unit is turned off, pressure will remain in the spray cup. If you pull the trigger back, a stream of fluid will flow. To prevent accidents, turn solution flow screw (Z Gun Fig. item#18) clockwise until it is completely closed. The trigger is now locked in the closed position.

Pro Series HVLP ZGun

Parts List and Diagram

Norvell Customer Service
888.829.2831
www.norvelltanning.com

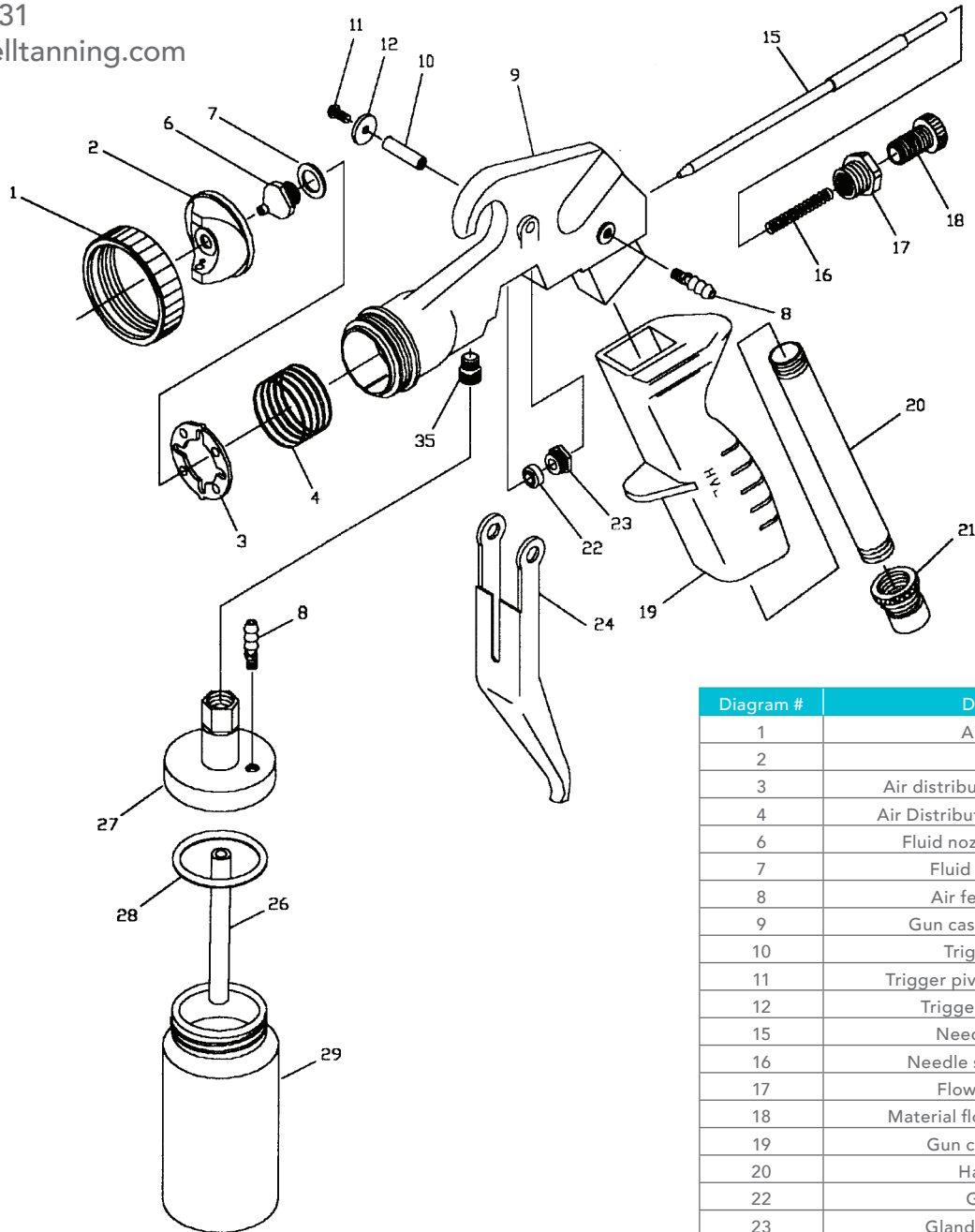

Diagram #	Description
1	Air cap ring
2	Air cap
3	Air distributor plate (stainless)
4	Air Distributor spring (stainless)
6	Fluid nozzle/jet (stainless)
7	Fluid nozzle gasket
8	Air feed connector
9	Gun casting (main body)
10	Trigger bushing
11	Trigger pivot screw (stainless)
12	Trigger screw washer
15	Needle (stainless)
16	Needle spring (stainless)
17	Flow screw insert
18	Material flow adjusting screw
19	Gun casting (handle)
20	Handle tube
22	Gland seal
23	Gland nut (stainless)
24	Trigger (stainless)
26	Material pick up tube
27	Lid assembly
28	Gasket (white poly)
29	8-oz. plastic cup
35	Fluid connector, 1/4" (stainless)

Z3000™

Additional Spray Gun Maintenance and Cleaning

After 50 hours of use or when necessary Norvell recommends the following maintenance be performed.

Check Cup Gasket, Nozzle Gasket, Gland Seal, Air Feed Connectors and Air Tube, Nozzle and Needle Assembly and Solution Feeder Tube for any damage or need for additional cleaning.

Clean or replace parts as needed. Call Norvell 888.829.2831 for genuine replacement parts. Failure properly maintain equipment may void your warranty.

Z3000 Turbine Unit Maintenance

- The turbine unit needs virtually no maintenance. The turbine has sealed bearings that are pre-lubricated, and no service is necessary. Periodically, the turbine unit air filters should be examined. Clean filters are critical to good performance and equipment longevity. Clean and/or change filters every 50 hours or when necessary.
- Your Norvell Z3000 HVLP Turbine has 2 replaceable filters located on either side of the turbine unit. The filters can be removed from the Noise Reduction Filter Covers by sliding them out of the bottom of the covers. No tools required!
- Rinse filters with warm water and gently press excess water out of filters with paper or salon towels. Do not squeeze or ring water out of filters. Allow filters to air dry. Do not install wet or damp filters in unit. Norvell recommends keeping an extra set of filters on hand for quick replacement as needed.
- Wipe excess dirt and dust away from surface of turbine. Dirty filters will reduce the air being drawn through the turbine, causing the unit to run abnormally hot, diminish spray performance and reduce the life of the motor.
- Clean and/or replace. Use the maintenance record sheet to keep track of your equipment use and make sure you change them every 50 hours.



Call Norvell at 888.829.2831 for genuine replacement filters.
Failure to clean or replacing the filters may void your warranty.

Troubleshooting Guide

Problem	Possible Solution
<p>SPRAY IS SPITTING, WEAK OR CEASES TO SPRAY</p>	<ul style="list-style-type: none"> · Is the solution cup securely connected? · Are the Air Feed Connectors and Air Feed Tube securely connected and undamaged? · Is the Cup Gasket in place and undamaged? · Is the Solution Flow Screw dialed within the appropriate range for the spray session? · Is the Air Speed Setting set within the appropriate range for the spray session? · Have you checked all air hoses for leaks and proper connection? · Have you broken your gun down to check for clogs within the nozzle or buildup around the gun needle?
<p>UNIT WILL NOT POWER ON</p>	<ul style="list-style-type: none"> · Is the equipment plugged into a properly grounded electrical outlet? · Is the equipment plugged into a 110v/15AMP outlet? · If the electrical outlet is a GFCI outlet does the outlet need to be reset? · Is the equipment plugged directly into an outlet or through another power source such as an extension cord or surge protector? If so, are all connections complete?
<p>SOLUTION IS SPRAYING TOO HEAVY</p>	<ul style="list-style-type: none"> · Is the Solution Flow Screw dialed within the appropriate range for a spray session? · Is the Air Speed Setting set within the appropriate range for the spray session? · Are you using the correct solution formulation for your equipment?
<p>SOLUTION IS LEAKING FROM THE FRONT OF MY GUN</p>	<ul style="list-style-type: none"> · Is the air cap ring properly tightened? · The fluid nozzle or needle may need to be replaced.
<p>SOLUTION IS LEAKING FROM AROUND THE CUP TOP</p>	<ul style="list-style-type: none"> · Is the solution cup securely connected? · Is the Cup Gasket in place and undamaged? · The Cup Gasket may need to be replaced.
<p>SOLUTION IS SPRAYING OUT OF MY GUN, BUT I AM NOT PULLING THE TRIGGER</p>	<ul style="list-style-type: none"> · The fluid nozzle or needle may need to be replaced.
<p>I THINK I AM GETTING TOO MUCH OVERSPRAY</p>	<ul style="list-style-type: none"> · Make sure you are holding your Spray Gun between 6 and 10 inches from the spray surface. · Adjust the Solution Flow Screw down to decrease the amount of fluid flow.
<p>AIR CONTINUALLY FLOWS THROUGH</p>	<ul style="list-style-type: none"> · This is normal as the HVLP Turbine and Gun is a “bleeder” applicator. This is necessary and desirable to ensure longevity of the turbine motor.

Warranty and Technical Support

For all technical questions please call Norvell, A Division of Sunless, Inc. at 888.829.2831.

For spraying technique visit www.norvelltanning.com.

TECHNICAL SUPPORT

Available Monday–Friday | 8am–5:00pm, CST.

Norvell Sunless Solutions

855.450.3500

www.norvelltanning.com

Norvell, A Division of Sunless, Inc.

The Norvell Mobile Z3000 Turbine is **warranted** by Norvell Spray Systems for a total period of **two** years from the ORIGINAL date of purchase by the ORIGINAL PURCHASER. Proof of purchase should be included and all SHIPPING CHARGES to be pre-paid when sending back to Norvell for repair.

Norvell Spray Systems, upon examination of the machine/equipment will replace or repair at their discretionary defects in material or workmanship.

This **warranty** does not include:

miss-use, damage, neglect, alterations, disassembled equipment or modifications, lack of maintenance, cleaning, water damage to electrical parts and **incorrect voltage connection**.

This **warranty** in lieu of all other express warranties, any warranty implied by law, including but not limited to implied warranties of merchantability to fitness, is excluded to the maximum extent permitted by law and, if not excludable, it is limited to the duration of the express warranty.

No representative or person is authorized to extend this warranty or to create for Sunless, Inc./Norvell, any other liability in connection with the sale of any **Norvell Spray System** product.

Sunless, Inc./Norvell shall not be liable for any consequential, incidental, or special damages of any kind directly or indirectly resulting from breach of any express or implied warranty.

Norvell, A Division of Sunless, Inc.
Customer Service 888.829.2831 or 615.529.1250
www.norvelltanning.com

**DO NOT USE EQUIPMENT BEFORE
READING THIS MANUAL!**

This manual contains important warnings and instructions.
Please read these instructions carefully and keep for your reference.